

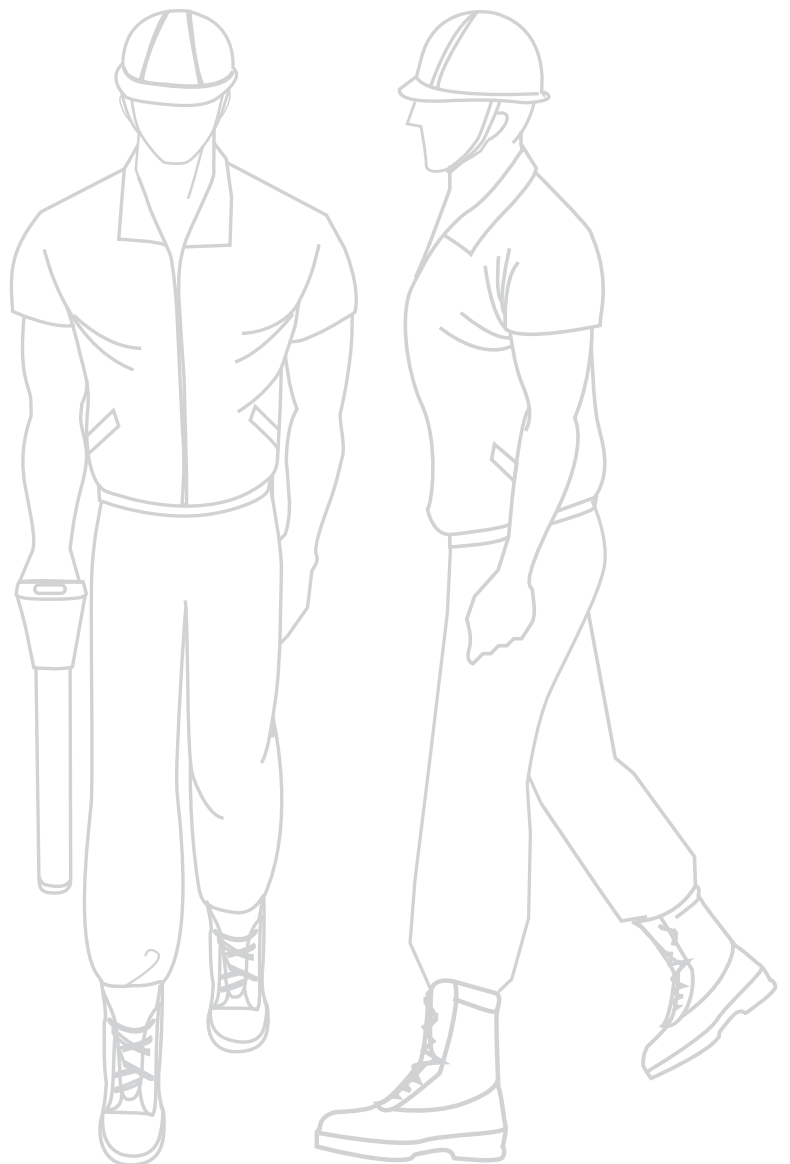

vCam Series User Manual
vCam Digital/View-Pushrod CCTV
Inspection System
Version 1.75 (English)



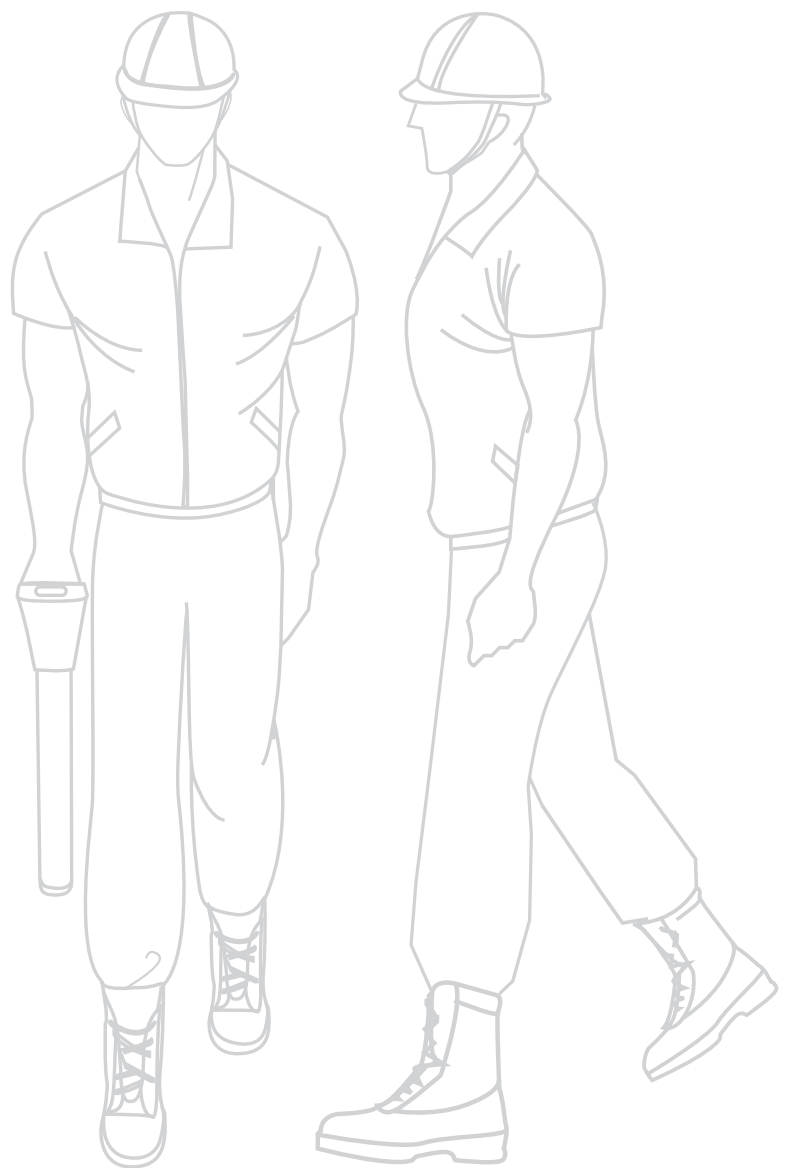

Table of Content

1.0	1	INTRODUCTION
1.1	1	SYSTEM FEATURES
1.2	2	SYSTEM COMPONENTS
1.3	2	IMPORTANT NOTES
1.4	3	MODEL and SERIAL NUMBERS
1.5	3	COMMAND MODULE, DISPLAY, KEYBOARD & MPEG (vCamDigital) – CONTROLS
1.6	5	KEYBOARD FUNCTION KEYS
1.7	6	CABLE REEL COMPONENTS
1.8	7	INTERCONNECT CABLE
1.9	7	WARNING - THE REEL
2.0	8	SETUP
3.0	9	USING THE VCAM
4.0	10	TITLER
5.0	11	RECORDING AND PLAYBACK – VCAM DIGITAL
6.0	12	COPYING VIDEO (from the MPEG recorder/ player to a Computer)
7.0	13	LOCATING THE CAMERA
8.0	14	SERVICE & SUPPORT
9.0	15	GENERAL SAFETY INSTRUCTIONS
10.0	16	HEALTHY AND SAFETY



INTRODUCTION

1.1 SYSTEM FEATURES

The vCam Digital/View System provides video images from inside pipes, ducts and chimneys. The vCam Digital includes an internal MPEG4 recording/playback device and software for recording the images seen, adding data, text and audio. The vCam View does not have these features. With this exception the use of both systems is the same. This manual serves as User instructions for both.

Command module

The command module houses the electronics and controls to operate the system and a LCD display for viewing. Also included in the control module are rechargeable batteries to power the system. The vCam can also be powered by an external 12V DC 3A source or by mains power.

The vCam Digital includes a MP4 recorder for recording and playing back the video images and software that enables titles, date, time, distance and an audio commentary to be added to the images recorded.

Both vCam View and vCam Digital include a video out function enabling video to be recorded by an external recording device. (VCR or video camera)

Cable reel

The cable reel is used to store and deploy the pushrod reinforced cable.

There are three sizes of cable reel – the standard (type “C”) is a Cart type assembly in stainless steel, and holds up to 200ft/60m of cable., the mini reel (type “M”) is also manufactured in stainless steel and holds up to 100ft/30m of cable. The largest reel (type “P”) is of painted (powder coat) construction and is used for 400ft/120m lengths of pushrod cable.

This epoxy/Kevlar reinforced pushrod cable enables the user to push the camera considerable distances along a pipe, but retains sufficient flexibility to pass through tight bends and “P” traps. The cable comes in two diameters - 10mm - generally used for small diameter pipes (up to 4inch/100mm) and shorter distances (up to 100ft/30m), - and - 12mm cables used for larger pipes and longer distances. Sensors to indicate how much pushrod cable is deployed are housed in the reel the length deployed is displayed on the control module front panel & the display.

A spring “termination” assembly is used to mount the camera to the pushrod cable, and provides additional flexibility to push the camera around bends and through “P” traps. The “termination” assembly also includes a transmitting sonde to enable it to be located from the surface using a pipe and cable locator with 512Hz, 640Hz or 33kHz modes (some limitations with 33kHz). The sonde is positioned approximately 16inches/ 400mm behind the head of the camera.

Camera module

All cameras are of stainless steel construction and house a color CCD camera module. There are four cameras - standard and self leveling versions for each of the two (pushrod) cable sizes. Incorporated in the camera assembly are ultra bright LED’s to provide illumination. The number of LED’s vary dependent on the diameter of the camera.

1 INTRODUCTION

1.2 SYSTEM COMPONENTS

The systems includes the following :

The vCamView

- Control module including internal rechargeable batteries and power supply/charger
- Cable reel includes pushrod cable, sonde and camera
- Mains power cable
- Interconnect cable (for connecting cable reel to control module)
- Vivax User Manual

The vCamDigital

- All of the components of the vCamView: plus.....
- Internal MPEG4 recorder and playback unit
- Keyboard and titler system
- USB data transfer cable

1.3 IMPORTANT NOTES

- It is recommended that the unit is not left on charge for excessive periods of time. This will not damage the unit, but will shorten the batteries life. Recommended charging time is 4 - 6 hours. The charger should not be turned off/on again during the charging cycle – this could result in over charging and damage to the unit/batteries or reduction of the battery life.
- Power Supply/battery charger is internal and operates on 100-240V AC 1A, 50Hz/60Hz power systems. 100-240V AC 1A power source must be grounded (earthed)
- External 12V DC 3A power source will only run the unit, it does not charge the internal batteries.
- The period of time the vCam can be used on a single charge of the batteries can be extended by having the auxiliary functions turned off when not in use. These included Sonde, Microphone, and camera lights. Using the unit in "CAMERA" mode (instead of MPEG mode) also uses less power.
- The sonde, in some circumstances, can cause interference on the video being viewed/recorded. It is recommended that the sonde is turned off, unless it is actually being used for location. This also saves power.
- The SD slot on the front panel is for programming the MPEG4 player/recorder only. It cannot be used for copying data. To copy data plug a USB cable into the "DATA" socket on the front panel. To upgrade software – turn off the vCam - plug the SD card into the slot – turn on the vCam, and wait until the main menu appears (this will take several minutes).
- Any computer with USB ports running Windows XP or Vista operating system can be used to import and play video files from the vCam.

1.4 MODEL and SERIAL NUMBERS

For quality control and support purposes each of the main modules of the vCam View/Digital has its own model and serial number.

Control Module – model and serial number label is on the base of the housing.

Reel Assembly – the model and serial number label is on the reel frame.

Camera – the model and serial number is etched on the body of the camera.

NOTE. Always quote the appropriate model and serial number(s) in all communication with the factory, or authorized service centers.

1.5 COMMAND MODULE, DISPLAY, KEYBOARD & MPEG (vCamDigital) – CONTROLS

The command module contains all of the the controls for the operation of vCam View/Digital system. The controls and connector panel are shown as below.

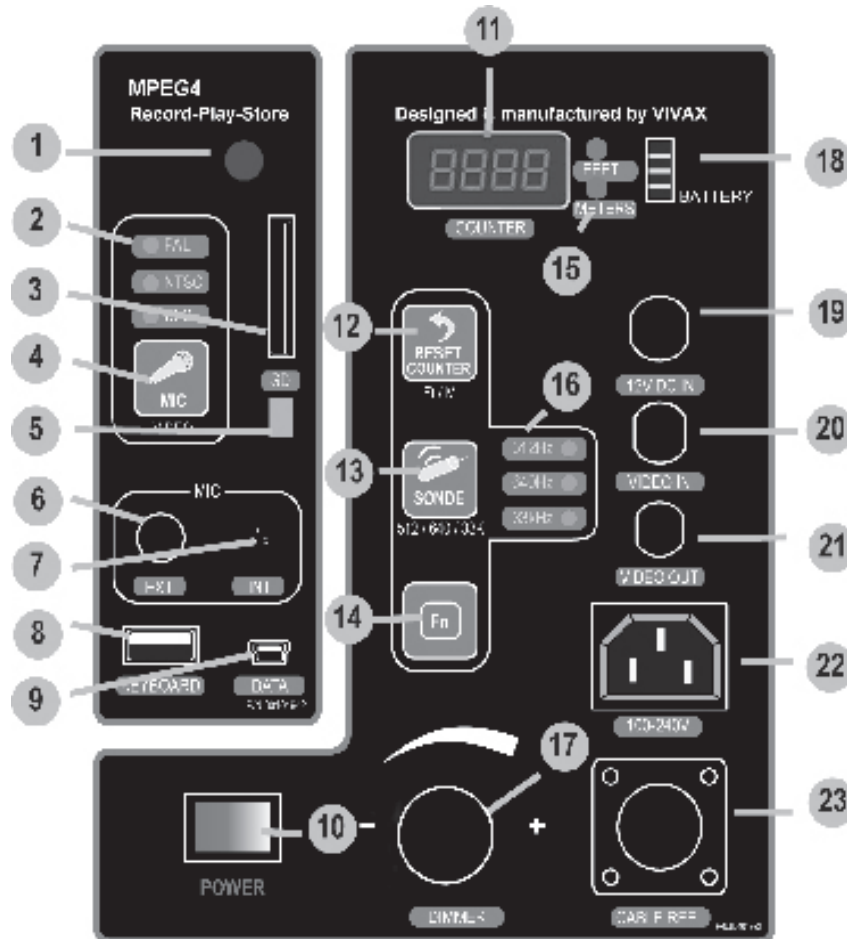

1 INTRODUCTION

Control panel key to functions:

No.	Description
1	Infra red receiver (for MPEG)
2	PAL / NTSC & Microphone on/off indicators
3	SD / MMC slot
4	Microphone on/off and indicator
5	Recorder activity / status indicator
6	External microphone socket
7	Internal microphone
8	USB Keyboard
9	USB Data transfer
10	System main power On / Off switch
11	Counter display
12	Reset the counter to zero
13	Sonde On / Off button
14	Function key (see below)
15	Feet / Meter indicator
16	Sonde frequency (512/640Hz/33kHz) indicator
17	Dimmer control for LED camera lights
18	Battery charge indicator
19	12V DC socket (for external 12V DC source (Car)
20	Video input (AV)
21	Video output (AV)
22	Mains power – IN
23	Interconnect cable socket

Combinations Functions keys:

Combinations	Functions
Fn and microphone button (#4)	Toggles PAL & NTSC video system
Fn and reset counter button (#12)	Toggles feet & meters
Fn and Sonde button (#13)	Toggles 512Hz – 640Hz – 33kHz

The LCD has it's own controls, these are in the form of a pushbutton keypad located in the recessed area close to the display . They function as follows:

Camera/MPEG4: Switches between Camera view, VGA view (not used) and MPEG view

Menu : used to selected items to adjust

Direction Arrows: used to adjust items selected.

Items that can be adjusted from the menu include:

BRIGHTNESS, CONTRAST, COLOR, SHARPNESS and VOLUME.

1 INTRODUCTION

Items that can be selected or set from the front panel

- Power on, power off.
- Video System – The vCam View/Digital is designed to use with PAL or NTSC system – The video/audio components in the vCam View/Digital adjust video format automatically to suit the camera fitted. PAL and NTSC can also be set manually, by pressing F2 on the keyboard or by holding down the “Fn” key and pressing the “VIDEO” button.
- Counter mechanism. The counter display the length of push cable deployed. Press F6 on the keyboard or “RESET COUNTER” key on the front panel to ZERO the counter (counter will count up or down, but will not display negative numbers). The counter display can be toggled to either “feet” or “meters” by pressing F3 on the keyboard or holding down the “Fn” button, then pressing “RESET COUNTER” on the front panel.
- Dimmer/off control for Camera lights (ultra bright LED’s). This is used to dim or brighten the camera lights, or turn them off to save power when the camera is not in the pipe.
- LED’s confirm on the front panel confirm the settings of PAL, NTSC, Microphone (on/off), and frequency (512Hz, 640Hz, 33kHz)

1.6 KEYBOARD FUNCTION KEYS

The main software setup functions can be controlled by using the “Function Keys” on the keyboard. The keyboard can also be used as an alternate way to set some functions controlled by key pad buttons on the front panel.

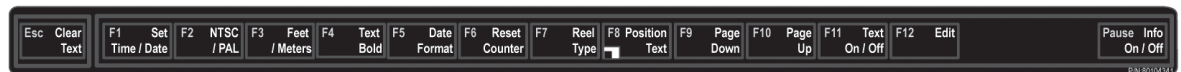

- ESC : Clear all text on the screen and previous pages
- F1 : Date and time setting
- F2 : Toggle between NTSC and PAL video systems
- F3 : Toggle between feet and meters
- F4 : Add bold or background to text (makes it easier to read)
- F5 : Toggle between MM/DD/YYYY, DD/MM/YYYY, and YYY/MM/DD date format
- F6 : Reset counter to Zero
- F7 : Selects Reel Type (Type-C, Type-P, Type-M) to ensure counter accuracy
- F8 : Changes the position of titler content
- F9 : Page Down
- F10 : Page Up
- F11 : Toggle titler content On/Off
- F12 : Edit / Hold titler text
- PAUSE: Info On/Off (battery indicator, distance, reel type, date and time)

Note : If the text editor appears not to be functioning press F12 as the keyboard may be set to HOLD

1 INTRODUCTION

1.7 CABLE REEL COMPONENTS

The Cable Reel features are shown below

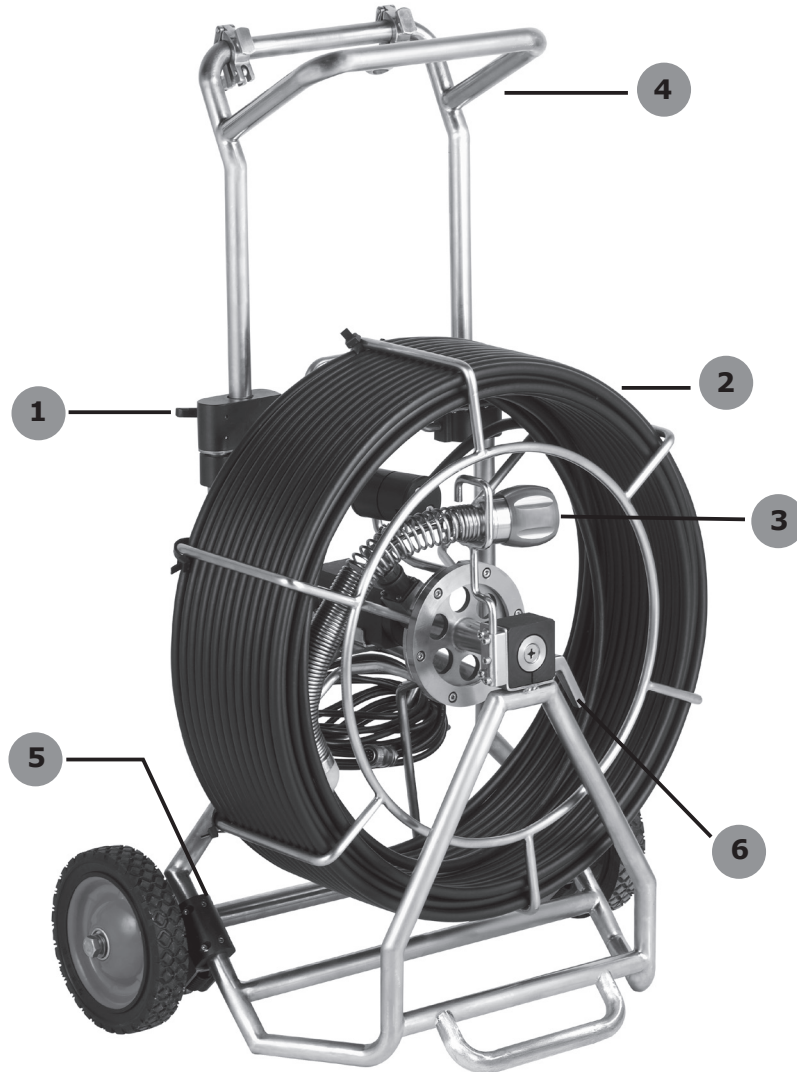

Functions:

NO.	Description
1	Handle locking levers
2	Cable & reel
3	Camera
4	Adjustable handle (Height)
5	Shock absorbed system
6	Brake

1 INTRODUCTION

1.8 INTERCONNECT CABLE



This cable is to connect the command module with cable reel. The 90 deg plug fits to the cable reel (and is normally left connected). The straight plug fits the socket on the control module, and is locked in place by the knurled locking collar. Pull on collar when connecting and remove the plug from the socket.

1.9 WARNING - THE REEL



If the brake is released completely the Pushrod cable will try and unwind itself. It can move very quickly



The brake should always be partially applied to slow down cable deployment. Care should be taken when stopping the cable deploying to avoid injury

SETUP

Setting up the vCam View/Digital system is easy.

The control module can be placed on the ground and the handle can be rotated (by pulling out both of the contoured knobs, and moving the handle) to set a comfortable viewing angle. Alternately the control module can be mounted to the reel (cart type "C") using the two brackets on the handle (optional) (ALWAYS position the handle downwards in parallel with the front panel when putting the control module on top of the reel – this allows the lid/keyboard to rest on the handle for easy use.)

Open the lid of the system – this can be removed or left attached to the command module. (there is a storage space inside the lid under the keyboard)

Keyboard – plug the keyboard into the command module (the keyboard can also be removed from the lid, by sliding the release and lifting the metal plate on which it is mounted).

Interconnect cable – ensure that the interface cable plug is correctly connected at the reel, and connect the other end to the appropriate socket on front panel. Ensure that the plug is aligned correctly before pushing into place – locate the plug into the socket using the index slot provided – pull the knurled ring to release the lock when plugging in or unplugging.

Power input – Plug the mains cable into the front panel of control module and the other end into an available (grounded) power source (100-240V AC). Alternately plug in a 12V DC power source capable of supplying at least 3A on a continuous basis. The center pin of the 12V DC "power in" socket is "+" and the outer ring is "-". The 12V DC power input does NOT charge the internal batteries – it only serves to run the unit from a 12V DC external source.



Microphone (vCam Digital only) – if an external microphone (optional) is being used plug it in. However if no external microphone is connected the internal microphone will be used. The microphone system has an on off control – turn the microphone on only when required (to avoid recording general "worksite" conversations. The microphone will only be active when the microphone switched on, and the microphone activated light is illuminated. If using the internal microphone – please get within 3 – 4 inches of the internal microphone when speaking. Always speak clearly and slowly. The audio will be recorded at the same time as the video (provided the microphone is switch on)

NEVER FORCE ANY OF THE PLUGS – always ensure that each of the connections are made before powering up the system.

USING THE VCAM

After setting up as described above,

- a) Switch ON, and check that the display is set to "Camera" mode.
- b) Check the LED's on the front panel to ensure that the settings you require for VIDEO, SYSTEM, SONDE FREQUENCY, SONDE ON/OFF, MICROPHONE ON/OFF are correct.
- c) Then press "RESET COUNTER".
- d) Partially release the brake on the vCam reel allowing cable to be pulled off the cable reel. If the cable starts to come off of the reel, without pulling, tighten the brake slightly.
- e) Push the camera and short distance inside the pipe and then use the dimmer control on the control module to adjust the lights to an appropriate brightness.
- f) This is all it takes – it is extremely simple.

4 TITLER

TITLER

This feature is provided on the vCam Digital. The "Titler" system enables the user to add information to the video images being recorded. Basic system information such as date, time, length of pushrod cable deployed, can be captured, and additional text – up to 16 pages of 9 lines with 24 characters per line can be added.



The titler is toggled on/off by pressing the "F11" key on the keyboard. The content of the titler can be erased by pressing "ESC" at any time the titler is on.

Text is entered using the keyboard. The "F4" key can be used to toggle on/off a feature that makes the text easier to read against the background. The content of the text can be moved to different parts of the viewing screen by using the key "F8"





If the titler information can be seen on the vCam Digital Display it will be recorded on the recorder, if it is not visible, it will NOT be recorded.

RECORDING AND PLAYBACK – VCAM DIGITAL

Record a video file

- a. Check the Display it should be set to "MPEG" mode – for recording, (it can be used in either "CAMERA" or MPEG mode when recording is not required)
- b. When the MPEG system is powered up, the Main Menu will appear use the arrow keys to select "RECORD NOW ", then press enter to start recording
- c. During recording press "/ENTER" to pause recording, to restart recording press "ENTER" again.
- d. Press "/BACK" to finish recording and saved the video file. Press MENU, then ENTER to return to the main menu

View a video file

- a. To view the file – from the main menu, use the arrow keys select the "VIEW RECORDED FILE" and press "/ENTER". This displays a list of "daily" folders containing you video (oldest first – newest last).
- b. Use the arrow keys to search the date the file was record. Press "/ENTER" to select folder. The individual video files are displayed (in a numeric sequence - oldest first, newest last) use arrow keys to select file and press "/ENTER" to play
- c. During playback press "/ENTER" to pause the playback, the press again to restart
- d. To stop the playback press "/BACK", then return the system to the main menu by pressing MENU then ENTER.

IMPORTANT – then MPEG recorder/player has its own operating system. If the vCam is turned off while the MPEG unit is in playback or record mode, an error file is created. The next time the unit is used this error file has to be detected, found and erased, then the files on the MPEG hard drive re-indexed. This is an automatic process and takes approx 3 minutes (more if the disk contains lots of files). The vCam can still be used in CAMERA mode while the MPEG is performing these utility functions, the utility functions will be performed in the background.

COPYING VIDEO (from the MPEG recorder/player to a Computer)

- a. Power **OFF** the vCam – this puts the MPEG player in “slave” mode – which enables your computer to use it as a USB hard drive.
- b. Plug in the USB cable between “DATA” port at the vCamDigital and USB port at the computer
- c. Using Windows Explorer or alternate computer tools – locate the MPEG drive which is called “VIVAX-VCAM” (or “Nugate”)
- d. All recorded video files on the drive are stored in a file(directory) called “REC_FILE”
- e. Using Windows Explorer or alternate computer tools, copy the file to your computer
- f. The video file can be viewed using Windows Media Player.
- g. You can also rename files and folders on the MPEG hard drive, but they must remain inside the “REC_FILE” to be accessed by the vCam.

IMPORTANT

If during playback with your computer doesn't show the image, install the CODEC provided on VIVAX vCam program CD. Alternatively, if you are connected to the internet, you can download the CODEC from www.vivax.biz in "download" section to download.

LOCATING THE CAMERA

The Counter will provide a guide to the length of cable deployed, which helps to establish the approximate position of the camera. This length of cable (selectable feet or meters) is displayed on the command module counter. The counter can be set to "Zero" at any time by pressing F6 on the keyboard or the "Reset" button on the front panel of the control module. The counter will count forward and reverse, but will NOT display values that are negative (ie less than Zero).

Pipe & Cable Locator - the vCam View/Digital is equipped with a Sonde transmitter to enable the exact position of the camera assembly to be located from the surface. This Sonde is located at the end of the camera spring assembly (about 16 inches /400 mm) behind the camera. A pipe and cable locator is used to locate the position and depth of the camera.

This sonde is activated by pressing the appropriate button on the front panel. It is recommended that the sonde is turned off when not in use, as in some circumstances it can cause interference on the video images being displayed. It also consumes power, which is relevant if running the system on the internal batteries.

Vivax manufactures the vCamLoc locator specifically for use with the vCam.

The vCamLoc can locate 512Hz, 640Hz, 33kHz the frequencies that the vCam transmits. It also has a "Power" mode for locating metallic pipes and cables that may be adjacent to the target pipe.

IMPORTANT – This does not remove or replace any requirement of the law, local ordinance, or your company/corporation to contact "Call Before You Dig" or Utility companies.

The vCamLoc

The vCamLoc has been designed for use with the vCamView/Digital systems. It can be also be used with CCTV inspections camera systems supplied by other manufacturers provided that they use 512Hz/640Hz transmitting frequencies (as many do). The vCamLoc also has 33kHz and "Power" mode.



SERVICE & SUPPORT

To contact Vivax for the name of your local Vivax Sales Representative or Service Center call or email the appropriate distribution center listed below

USA, Canada, Central & South America

Vivax Corporation
23-27 Bland Street
Emerson, NJ 07630
USA

T/Free 1-866-332-1688 (USA/Canada)

Tel# +1(201)265-5502

Fax# +1(201)265-5504

Web: www.vivax.biz
Email info@vivax.biz
sales@vivax.biz
service@vivax.biz

Asia Pacific

Vivax (Shanghai) Ltd
3F No.90, Lane 1122 QingZhou Rd.(N)
Shanghai, 200233,China

Tel# +86-21-5109-9980

Fax# +86-21-2281-9562

Web: www.vivax.biz
Email info@vivax-cn.biz
sales@vivax-cn.biz
service@vivax-cn.biz

Europe

SebaKMT
Mess-und Ortungstechnik GmbH
Dr.-Herbert-Lann-Str.6
96148 Baunach, Germany

Tel# +49 9544-680

Fax# +49 9544-2273

Web: www.sebakmt.com
Email info@sebakmt.com
sales@sebakmt.com
service@sebakmt.com

China

域华电子科技（上海）有限公司
地址：上海市徐汇区钦州北路1122号90栋3层
邮编：200233

电话：+86-21-51099980/81

传真：+86-21-22819562

Web: www.vivax.biz
Email info@vivax-cn.biz
sales@vivax-cn.biz
service@vivax-cn.biz

GENERAL SAFETY INSTRUCTIONS

Before using for the first time, please read the following items carefully:

1. In general the vCam can be used in either indoor or outdoor.
2. To ensure safe and reliable operation – Do not subject this unit to extreme temperatures, shock or impact.
3. Avoid getting moisture / water inside the enclosure.
4. To avoid the risk of electric shock do not open the sealed enclosure.
5. Nickel metal hydride (NiMH) rechargeable batteries pack
 - a. Do not remove or attempt to access the rechargeable batteries.
 - b. Use only specified charger for the rechargeable batteries. Use of an incorrect charger could result in damage to the vCam control module or fire.
 - c. Do not damage, crush or puncture batteries or subject to extreme heat or fire.
 - d. Dispose of these batteries in accordance with your company procedure.
6. Storage temperature: -20°C to +70°C (-4°F to 158°F)
7. Operating temperature: -10°C to +50°C (14°F to 122°F)
8. Camera water resistance up to 6 BAR
9. Reel water resistance comply to IP54, it's also can be hosed down on pressured washed.
10. Control Module water resistance (lid closed) comply to IEC 60529 (Light shower) and shock resistant (lid closed) comply to IEC 60069-2-31

HEALTHY AND SAFETY

This equipment is primarily used for inspecting sewer pipes, by professionals operating in the sewer industry, and maintained by professionals familiar with the health risks on maintaining equipment that has been in a sewer.

Such professionals will be protected by their own company's recommendations and work practices. If for any reason they are not, or are not familiar with such practices, please email Gavin_wong@vivax-cn.biz for a copy of the Health and Safety Document used by Vivax for employees involved in the demonstration, maintenance and handling of sewer camera systems.

www.vivax.biz

Printed in China